

BG mounting - fixed type

- ◆ Pneumatically operated mounting for installation in domelights etc.
- ◆ Opening angle 140° or 165°
- ◆ Fixed cross beam type for domelights with 800, 1.000, 1.300 and 1.600mm inner width of curb and a hinge size of 65 to 70mm
- ◆ Ideally suited for domelights:
Inner width = nominal width - 200mm
- ◆ Due to cross beam design, only small forces are introduced into the curb and domelight frame
- ◆ Space-saving due to flat design
- ◆ Ease of assembly by hanging the mounting from above into the curb or frame
- ◆ Available in 4 sizes with different pneumatic cylinders Type **P** (for selection of size, see drawing/table on page 2)
- ◆ As cylinder locks automatically in open position, unintentional closing is not possible
- ◆ Available in the versions "OPEN-CLOSE" and "OPEN only" ("OPEN only": SHEU has to be unlatched and closed by hand)
- ◆ Domelight locked in closed position by mechanical hook locking device **MHV** and adjustable locking bolt **EVB 3-M12** or extension set for ventilation **Set-L3** (see locking elements)
- ◆ Upper cross beams including preassembled hook locking device **MHV** (see upper cross beams)
- ◆ Standard connection for 6mm pipe
- ◆ Can be provided with additional electric or pneumatic ventilation function
- ◆ When ordering, please complete the dimensional sheet, and specify inner width



Accessories:

◆ **Accessories for mountings without ventilation function:**

Upper cross beams: Upper cross beams including preassembled hook locking device **MHV** (see upper cross beams).

EVB 3-M12: Adjustable locking bolt

◆ **Accessories for equipping mountings with ventilation function:**

Upper cross beams: Upper cross beams including preassembled hook locking device **MHV** (see upper cross beams).

Electrically operated ventilation with rack actuator:

Set-L3-M8 / ST 12-1/8: Screw M8 with cross pin dia.12mm, including 2 fixing plugs ST 12-1/8" for actuators Type E

Rack actuator Type E: 500 / 250N (push / pull force), (see Electric Parts Catalogue -> actuators)

E-300-230: 300mm stroke, 230V~ / 0,1A

E-500-230: 500mm stroke, 230V~ / 0,1A

Pneumatically operated ventilation with cylinder Type PODV:

Set-L3-M8: Screw M8 with cross pin dia.12mm

Cylinder with 32 or 40mm piston rod diameter, including swivel screw fitting (see cylinder),

PODV 32/12-300-12/6L: 300mm stroke

PODV 32/12-500-12/6L: 500mm stroke

PODV 40/12-300-12/6: 300mm stroke

PODV 40/12-500-12/6: 500mm stroke

For special types please inquire

SHE mountings Pneumactical BG mountings

BG mounting - fixed type

without ventilation

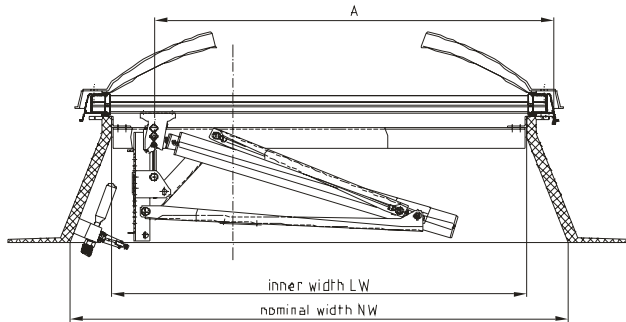

Type	NW	LW	Size A
BG1. 11	1000	800	765
BG2. 11	1200	1000	965
BG3. 11	1500	1300	1250
BG4. 11	1800	1600	1550

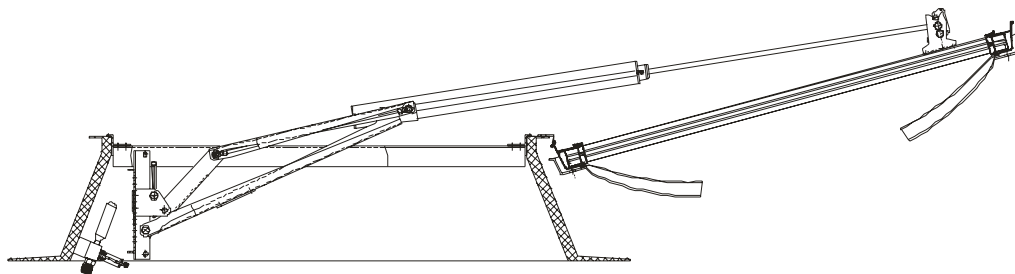

with ventilation

electrical

pneumactical

